

## Manual

### SP5 B Peristaltic Pump



**Remark:**

Access code for program changes or changes of system settings:

Password:

6299

Your password:

## CONTENT

<b>SPECIFICATION</b> .....	<b>4</b>
<b>DIMENSIONS</b> .....	<b>5</b>
<b>SAFETY INFORMATION</b> .....	<b>6</b>
HAZARD INFORMATION IN THIS MANUAL .....	6
<b>WARNING LABELS</b> .....	<b>7</b>
<b>GENERAL INFORMATION</b> .....	<b>8</b>
PERMISSIBLE APPLICATION .....	8
FUNCTIONAL DESCRIPTION .....	8
<b>DEVICE FEATURES</b> .....	<b>9</b>
<b>DISTRIBUTOR AND BOTTLES</b> .....	<b>10</b>
1x25 L COMPOSITE .....	10
4 x14 L DIRECT DISTRIBUTOR .....	10
24 x 1 L DIRECT DISTRIBUTOR .....	10
<b>DETAILS DIRECT DISTRIBUTOR 24 X 1 L</b> .....	<b>11</b>
<b>ELECTRICAL CONNECTIONS</b> .....	<b>13</b>
<b>PERISTALTIC PUMP -</b> .....	<b>15</b>
<b>PROGRAMMING MAIN MENU STRUCTURE</b> .....	<b>19</b>
<b>ANNEX – CALIBRATION VOLUME OF PERISTALTIC PUMP -</b> .....	<b>20</b>
<b>CIRCUIT DIAGRAM</b> .....	<b>22</b>

## SPECIFICATION

<b>Electrics</b>	
<b>Power supply</b>	230 V / 50 (opt. 60) Hz., 16 A fuse
<b>Power consumption</b>	Approx. 350 VA with cooling
<b>Environment</b>	
<b>Medium temperature</b>	0 to +40 °C
<b>Ambient temperature</b>	-20 to +45 °C
<b>Suction height</b>	Max. 8 m (at 1013h Pa)
<b>volume accuracy</b>	+/- 5 % at 250 ml average in a set of 10 samples
<b>General specifications</b>	
<b>Maintenance requirements</b>	Almost Maintenance-free, only cleaning and wear part (pump tube)
<b>Weight</b>	Approx. 75 kg with composite container, higher weight when using several bottles and/or glass bottles
<b>Dimensions (h x w x d)</b>	(Hxwxd) 1.100 (1.640*) x 760 x 745 mm *) with opened top
<b>Bottle variants</b>	Plastic: 1 x 25 L / 4 x 14 / 24 x 1,0 L
<b>Certification</b>	
<b>Certification</b>	CE, Sampling in accordance with ISO 5667-10, EN16479

Subject to change without prior notice

## DIMENSIONS

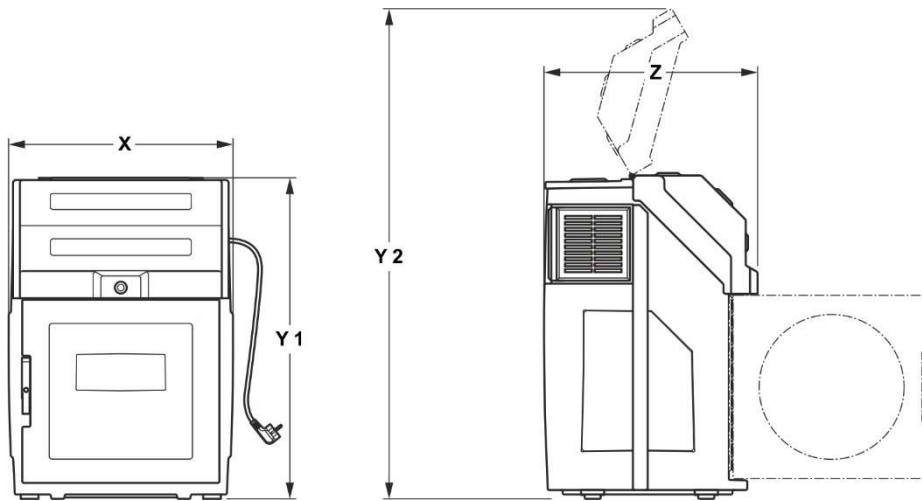

Dimension	X mm	Y 1 mm	Y 2 mm	Z mm
<b>SP5 B</b>	760	1100	1640	725

## Safety information

Please read the entire manual before the equipment is unpacked, set up or operated. Pay attention to all danger and caution statements. Personal injury or damage to the equipment could occur if they are not observed.

To ensure that the protection provided by this equipment is not impaired, do not use or install this equipment in any manner other than that specified in this manual.

## Hazard information in this manual



### DANGER

Indicates a potentially or imminently hazardous situation which, if not avoided, will result in death or serious injury.

---

---



### WARNING

Indicates a potentially or imminently hazardous situation which, if not avoided, could result in death or serious injury.

---



### CAUTION







Indicates a potentially or imminently hazardous situation that could result in

**Important note:** information that requires special emphasis.

**Remark:** information that supplements points in the main text.

## Warning labels

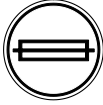
Read all labels and notices attached to the equipment. Personal injury or damage to the equipment could occur if they are not observed. Any symbol on the equipment will appear along with a caution statement in the manual.

	<p>This symbol, if noted on the instrument, references the user manual for operation and/or safety information.</p>
	<p>This symbol, when noted on a product enclosure or barrier, indicates that a risk of electrical shock and/or electrocution exists.</p>
	<p>This symbol may appear on the product and indicates the need for protective goggles.</p>
	<p>This symbol may appear on the product and identifies the connection point for the protective ground.</p>
	<p>When this symbol appears on the product, it identifies the location of a fuse or a current limiter.</p>
	<p>Electrical equipment marked with this symbol may not be disposed of in European domestic or public disposal systems after 12 August 2005. In conformity with European local and national regulations (EU Directive 2002/96/EC), European electrical equipment users must now return old or end-of-life equipment to the manufacturer for disposal at no charge to the user.</p> <p>For return for recycling, please contact the equipment manufacturer or supplier for instructions on how to return end-of-life equipment, manufacturer-supplied electrical accessories and all auxiliary items for proper disposal.</p>

## General information

### Permissible application

- The device can be used for sampling liquid, aqueous substances (water/waste water) with a temperature of up to 50 °C. The user is responsible for any possible danger emanating from the sampled medium and the resulting damage.
- The sampler is designed for operation in **non-hazardous areas** (no explosion risk).
- The sampler can be operated at ambient temperatures from -20°C to +50°C. We always recommend to shade the device.
- Sampling from **pressurized lines** is **not possible**, without specific accessories.

### Functional description

The equipment provides temporary storage for liquids of a specified volume so that they can be analyzed.

### Used Materials



In our devices different materials are used which come into contact with the sample.

These are depending on the device type PVC, PC, PS, glass, stainless steel, silicone or PE.

Depending on analysis requirements, we can also offer you alternative materials, e.g. different types of silicone or Teflon.

**Important Note:** The sampler is based on the model SP5 B



For the part of the basic programming, we refer to the standard manual "[Programming instructions for SP-TP-P6](#)"

## DEVICE FEATURES

1. Hood
2. Control with display and keypad
3. Connection for suction hose
4. Distributor arm
5. 24 segment Bottles 1 L
6. Bottle tray
7. Notch for position of bottle tray
8. Peristaltic Pump
9. Capacitive Sensor 2
10. Capacitive Sensor 1
11. Door of sampling compartment

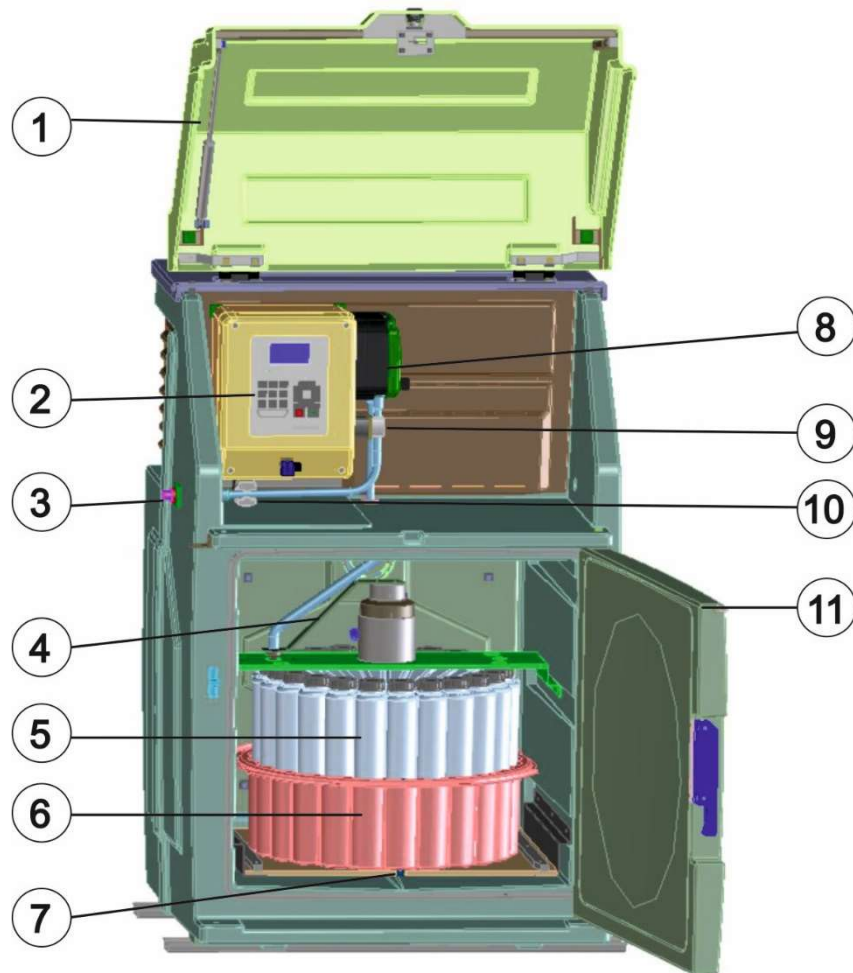

## DISTRIBUTOR AND BOTTLES

**1x25 L composite**



**4 x14 L Direct distributor**



**24 x 1 L Direct distributor**



## Details Direct distributor 24 x 1 L

It's a direct distributor, with 24 bottles

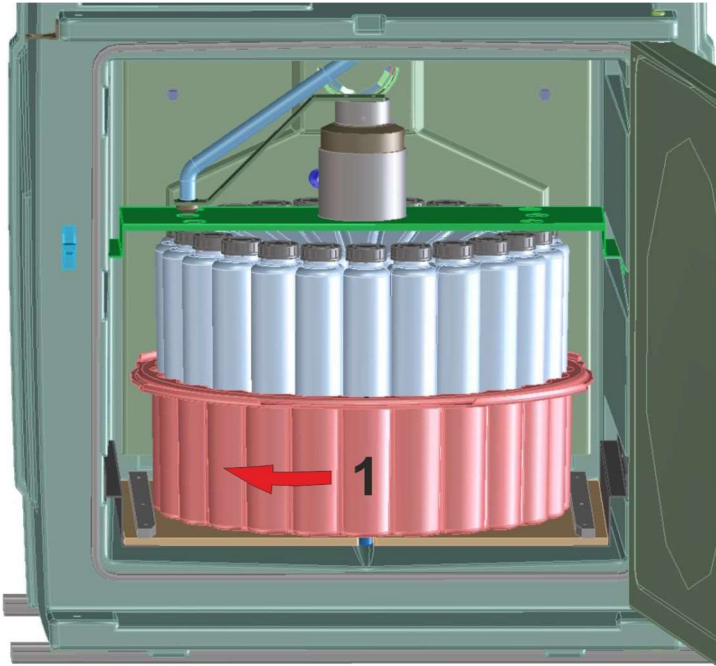

Bottles from top with filling direction

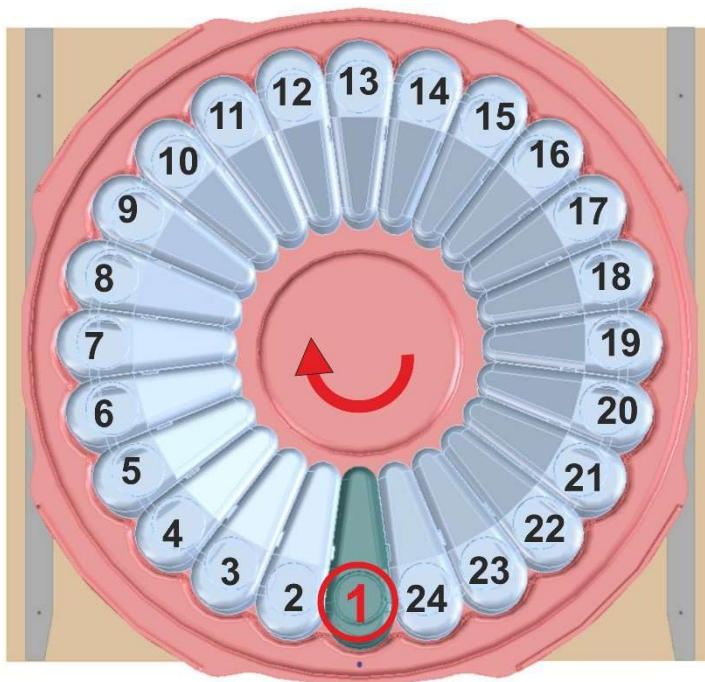

The bottles are in a bottle tray, which can be moved out

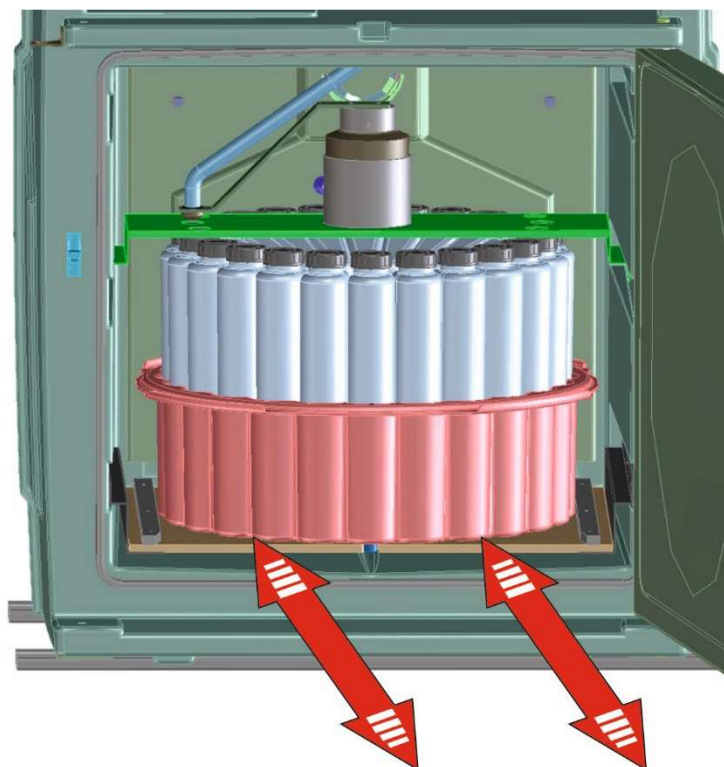

At the bottom of the tray is a bolt for positioning. If you move the tray back, take care to position the bolt in the notch.

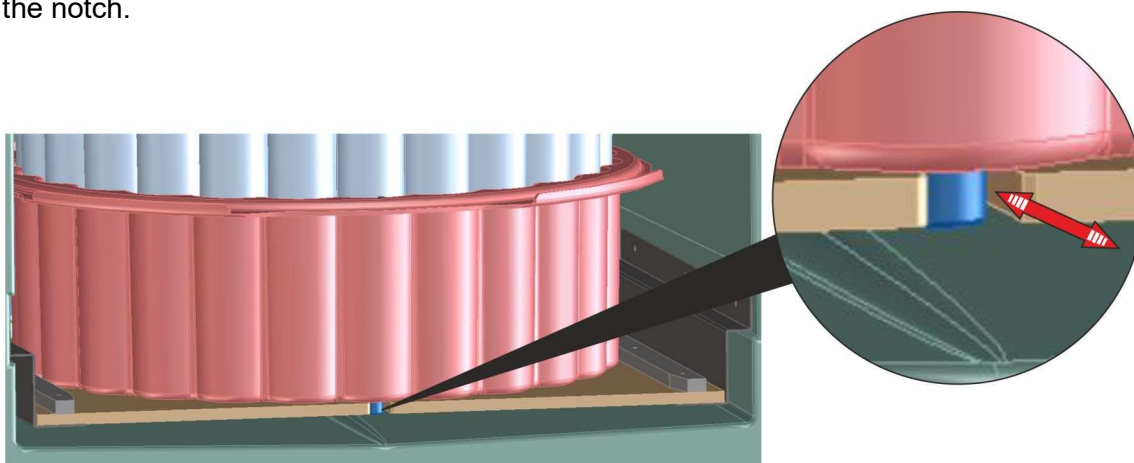

## ELECTRICAL CONNECTIONS

### Electrical installation

#### Prepare the electrical installation

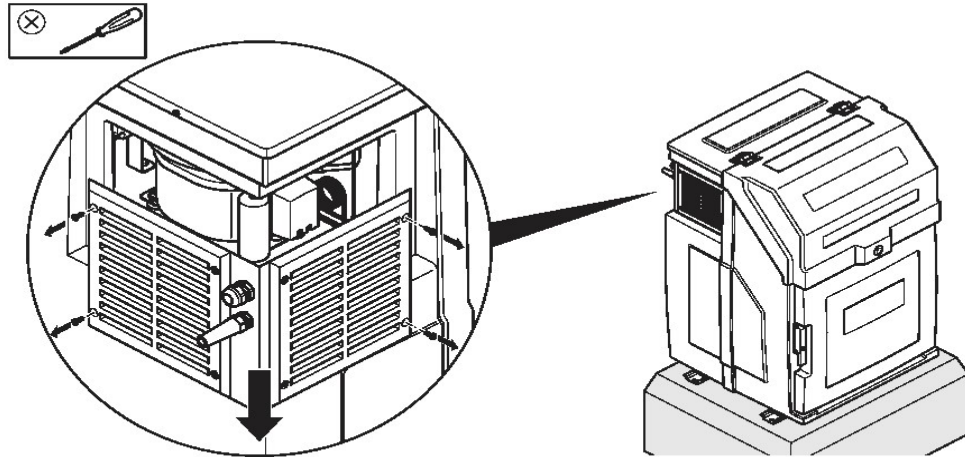

Loosen the screws and remove the cover (SB5 B)

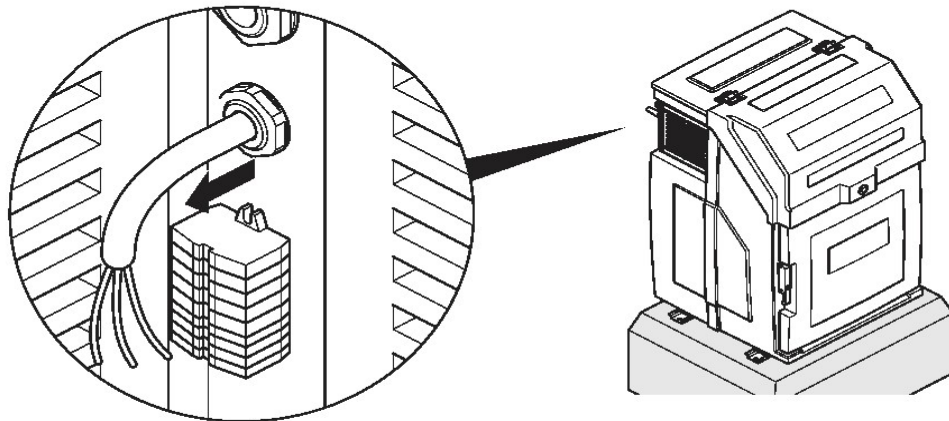

Feed cable through (SP5 B)

## Wiring diagram (SP5 B)

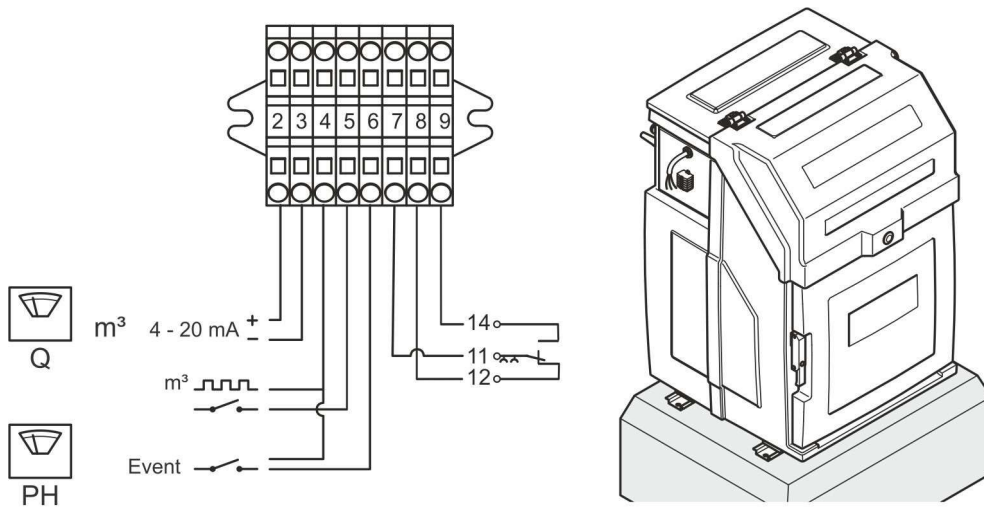

## Complete the electrical installation (SP5 B)

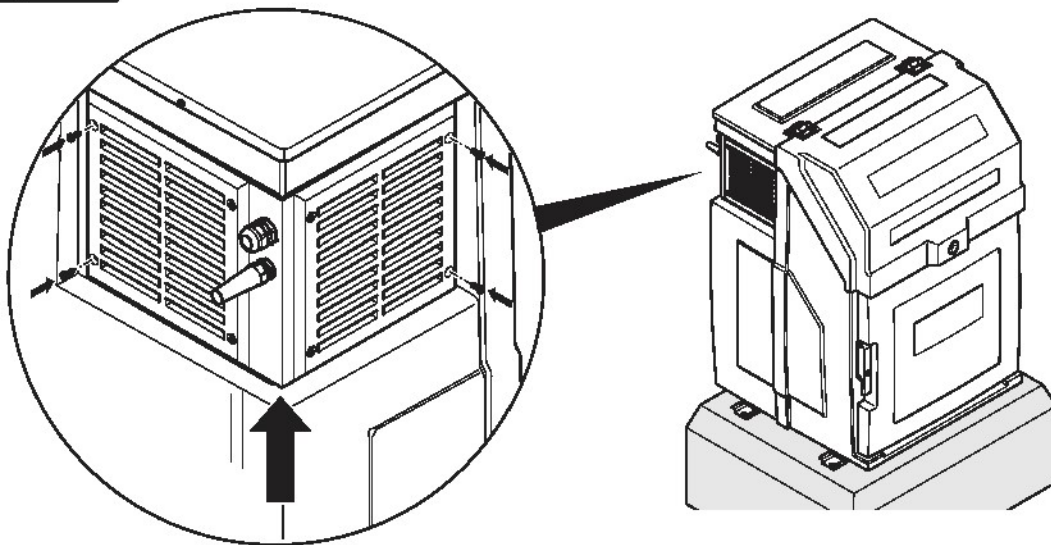

Attach cover

## PERISTALTIC PUMP -



### Important Note:

**Before you put the sampler into service, the system has to be calibrated!**

How to do the calibration is described in the ANNEX:

## PUMP TUBE REPLACEMENT



**Important Note:** Use of tubing other than that supplied by the manufacturer may cause excessive wear on mechanical parts and/or poor pump performance!

Inspect and clean the pump tubing and rollers on a regular basis.

Replace the tubing when deteriorated, at regular intervals.

Part.No. 0092216

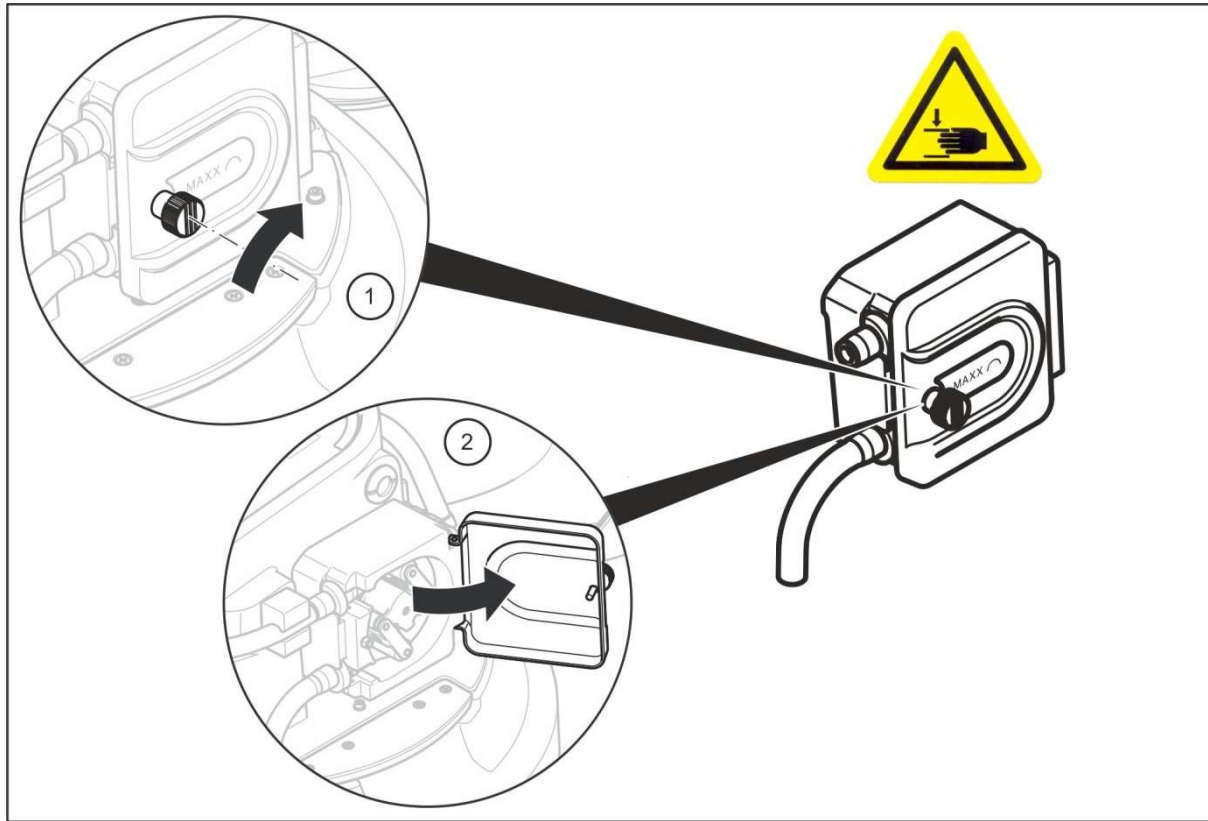

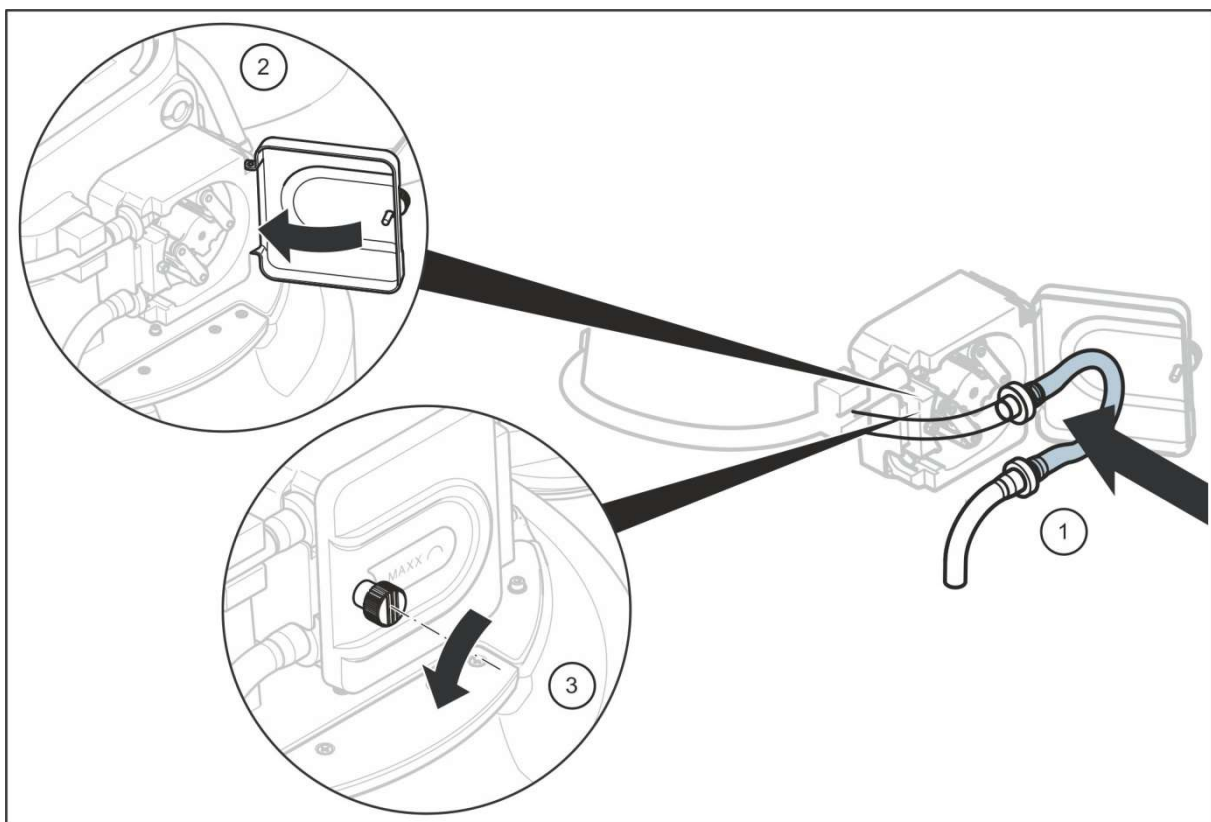
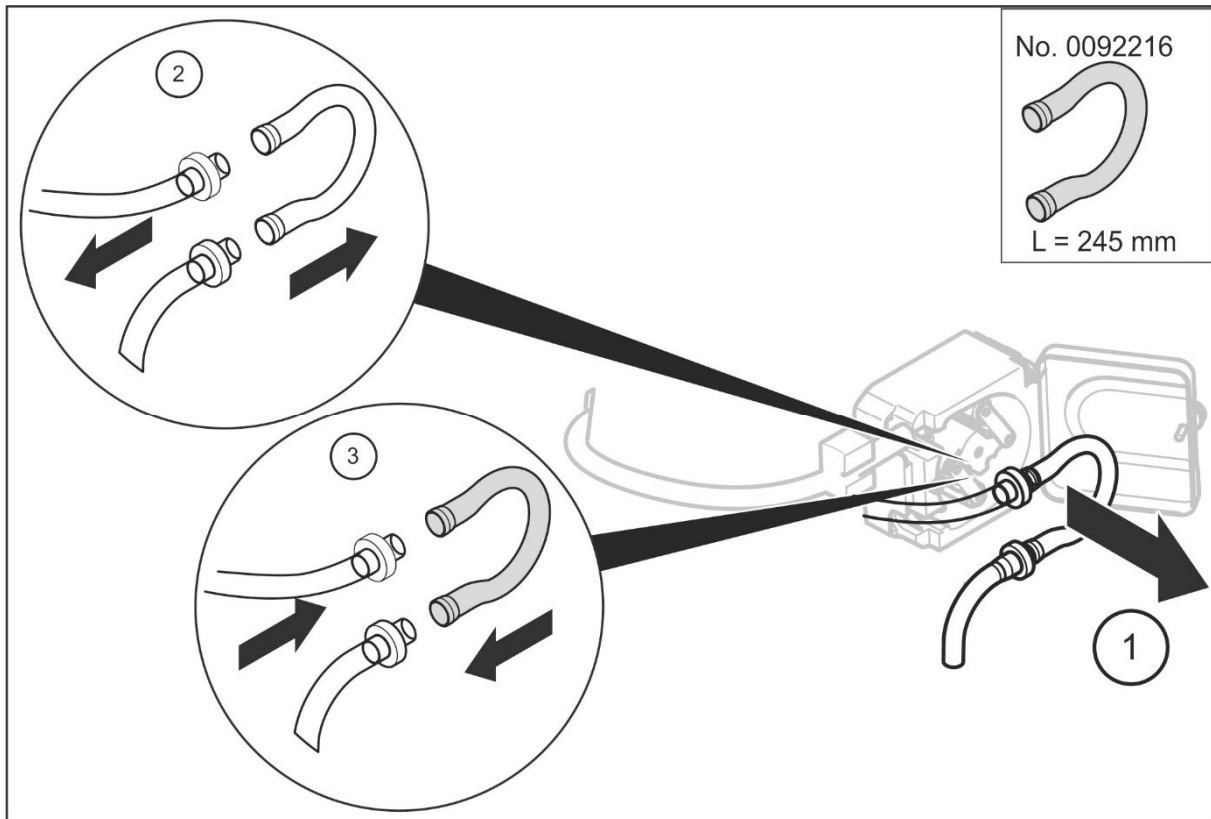



## Important Note:

The sampler measures the sampling volume with **2** capacitive Sensors. Depending to the sampling point, after some time can be dirt in the silicon tube. If you get error messages (error water sensor), you have to **clean the tube!**

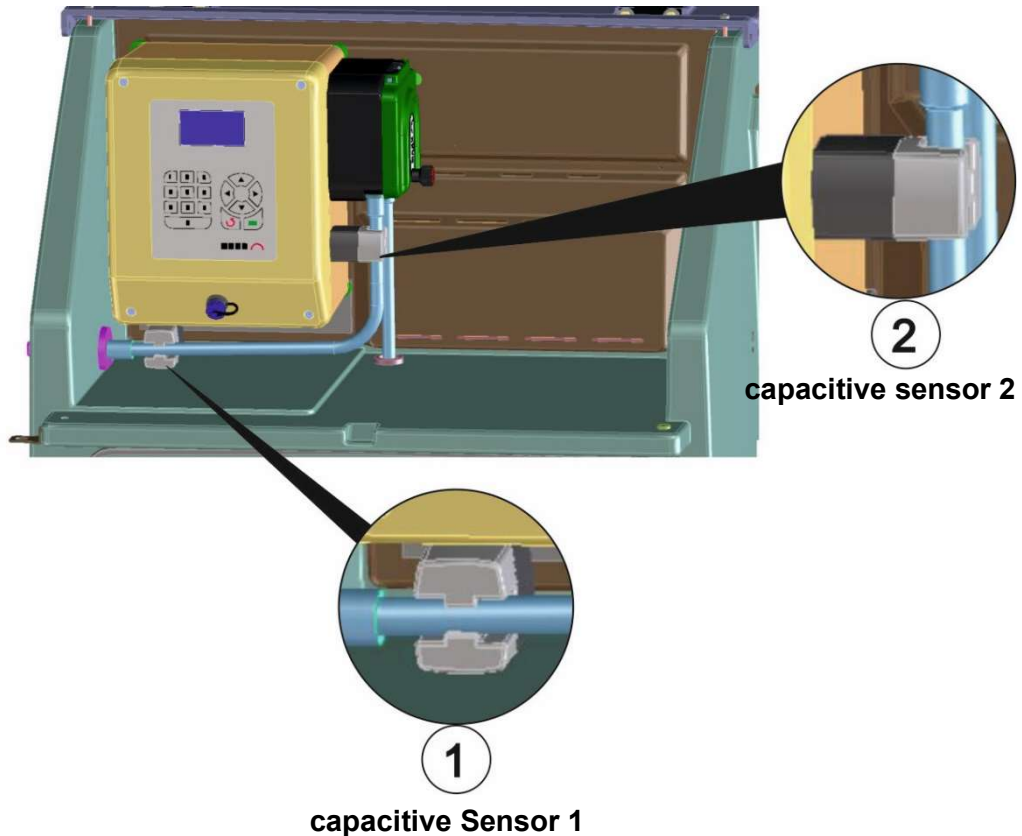

**TIP:** A very simple way to clean the tube inside is the use of a pig (sponge). Cut a piece of sponge with approx. 12x12 mm. Go to the menu:

### **DIAGNOSTICS / TEST ► COMPONENT TEST ► PUMP.**

You can now manually run the pump forward (suction) and backward (purging). Moisten the sponge, hold it to a tube end and let it “suck” through the tube. It works in both directions. Repeat this until the hose is clean again.

You can also buy pigs with different diameters ready to use e.g. Cleaning/Sponge balls like the picture shows



## PROGRAMMING MAIN MENU STRUCTURE

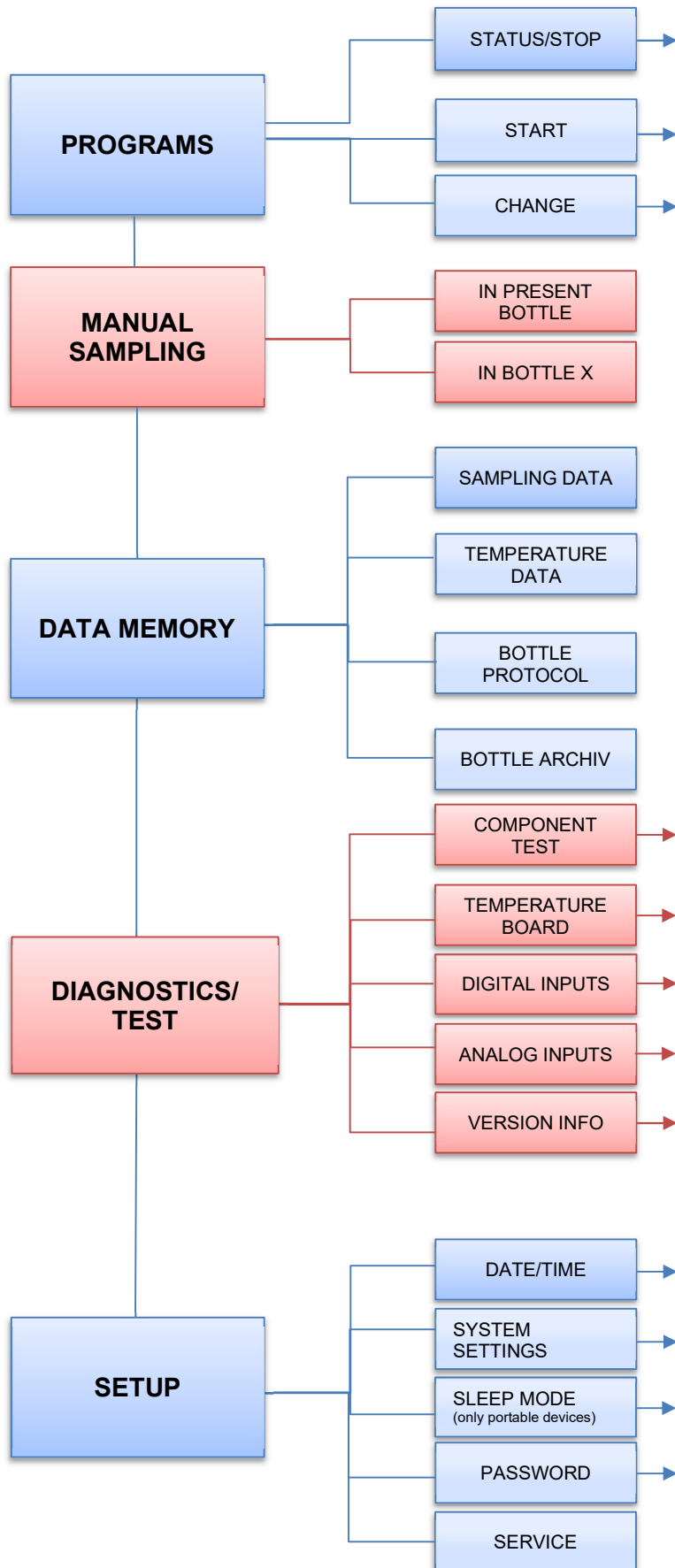

## ANNEX – Calibration Volume of PERISTALTIC PUMP -

The single sample volume is defined by 2 capacitive sensors and a measuring tube and is highly accurate.

We recommend to calibrate the system every time a new sampling point and from time to time, depending on the customer-specific accuracy requirement.

The Peristaltic Pump enables as well a flow-proportional sample extraction, that means the sample volume varies automatically according to an analog flow signal (0/4 - 20mA).

Example:

- the selected range is 0 to 20 mA
- the max. sample volume at **20 mA** is fixed to **200 ml**.

That means at an analog signal of e.g. **10 mA**, a **100 ml** sample would be extracted. Thus the sample extraction is always proportional to the flow.

At this system the sampling interval is **fixed** (e.g. every 10 min.) and the sample volume **varies** (the volume changes according to the mA signal).

Thus a sample extraction **proportional** to the flow is guaranteed.

When putting the sampler into service, the system has to be **calibrated**. How to do the calibration is described in the following section:

**SET UP** → **SYSTEM SETTINGS** → **VAR CALIBRATION**



### CALIBRATION -Peristaltic Pump-

#### 1. Start of calibration

CALIBRATION is always the 1<sup>st</sup> step on-site with any new sampling point.



#### 2. Start UPPER value

There are 3 consecutive calibration cycles which are started automatically.



Please collect the samples **of all 3 cycles** in a measuring glass!  
 (Capacity  $\geq 2$  liters)

**3. ACTUAL VALUE upper value**

Please enter the total volume of the 3 cycles.



The upper value is calibrated



**4. Start LOWER value**

There are 3 consecutive calibration cycles which are started.  
 Please collect the samples **of all 3 cycles** in a measuring glass!

(Capacity  $\geq 200$  ml)



**5. ACTUAL VALUE lower value**

Please enter the total volume of the 3 cycles.



**6. INFO after the completion of the calibration of the lower value.**

**Now, the system is calibrated and can be operated!**





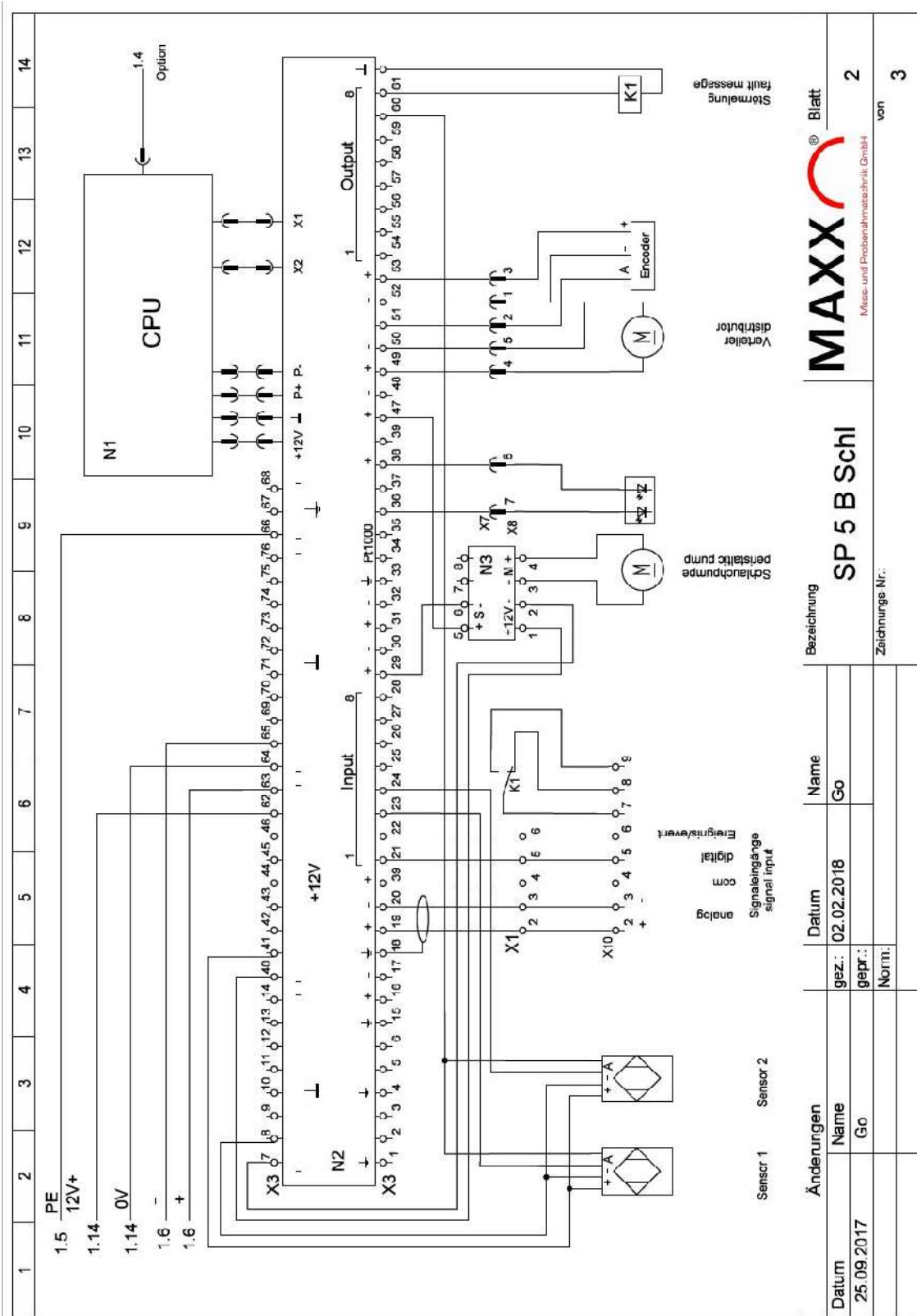

MAXX® Blatt 2

Mess- und Probenahmetechnik GmbH  
von 3

Bezeichnung  
SP 5 B Schli

Änderungen		Datum	Name
Datum	gez.:	02.02.2018	Go
25.09.2017	gepr.:	Norm.	
	Zeichnung Nr.:		

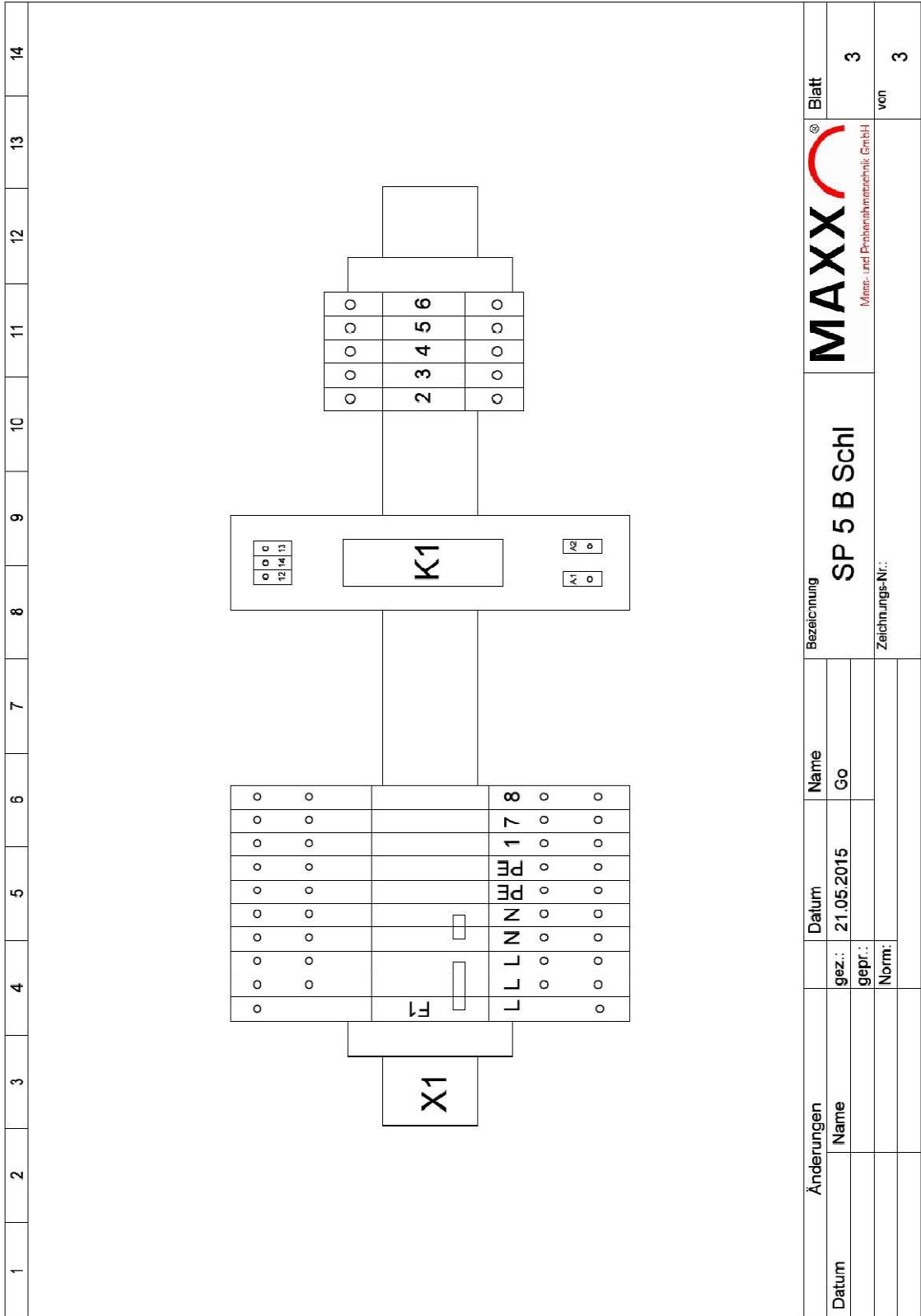

<b>Anderungen</b>	<b>Datum</b>	<b>Name</b>	<b>Blatt</b>
<b>Name</b>	<b>gez.:</b> 21.05.2015	<b>Name</b> Go	<b>3</b>
	<b>gepr.:</b>		<b>von</b>
	<b>Norm:</b>		<b>3</b>
		<b>Bezeichnung</b>	
		<b>SP 5 B Schli</b>	
		<b>MAXX®</b> <small>(Mess- und Probenahmetechnik GmbH)</small>	